

V5422L / V5422E ACTUATED BUTTERFLY VALVES

SPECIFICATION DATA



GENERAL

The V5422L and V5422E Actuated Butterfly Valves are suitable for heating and cooling applications as well as in boiler management systems. They can also be employed for general services, water treatment, etc.

The V5422L series is equipped with floating-control actuators (230 V, three-point).

The V5422E series is equipped with modulating-control actuators with a standard control signal of 0...10 V (2...10 V, 0...20 mA, and 4...20 mA also possible).

The actuators and valves are delivered factory-mounted. The position control and the end stops are completely justified.

FEATURES

- With factory-mounted electric actuator
- Centric butterfly valve with elastomer liner
- Wide DN range (DN250 through DN400)
- For heating water containing up to 50% glycol
- Wafer body
- For modulating and floating control
- Maintenance-free control drive
- Mechanical setting indicator
- Manual adjustment wheel and declutch button
- Ample reserve torque
- Sizable terminal compartment for cabling
- Long unit lifetime

SPECIFICATIONS

Valves

Sizes	DN250...DN400
Nominal pressure rating	PN10
Shut-off pressure	10 bar
Tightness	bubble-tight
Temperature of medium	-10...+95 °C (DN250-300) +20...+95 °C (DN350-400)
Body	Wafer, ductile iron GG25 Rilsan/epoxy-coated
Liner	EPDM EW (max. 130 °C)
Disc	GGG40, epoxy-coated
Shaft	Stainless steel 1.4028 (AISI 420)

Actuators

Motor voltage	230 Vac (±10%), 50 to 60 Hz
Current, running time	See Table 1
Angle of rotation	90°
Duty cycles	max. 30% (class S4 IEC60034)
Running noise	65 dBA
Ambient temperature	-20...+70 °C
Motor insulation	class F according to VDE 0530
Protection class	IP67 as per DIN 40050
Cable gland	M20, cable Ø 9...16 mm

Table 1. Type list for different valve sizes and corresponding data

floating version	modulating version	actuator current (A)		run time (sec)	actuator torque (Nm)	valve size (DN)	Kvs (m ³ /h)	weight (kg)
		nominal	start					
V5422L1006	V5422E1001	1.2	1.7	30	600	250	4800	39.2
V5422L1014	V5422E1019	1.2	1.7	30	600	300	7000	48
V5422L1022	V5422E1027	2.0	3.0	30	800	350	8300	60
V5422L1030	V5422E1035	1.2	1.7	60	1200	400	11000	87

GENERAL CHARACTERISTICS

Position Indication and Running Status

The actuator's position is indicated by a mechanical pointer located behind a window on the actuator's cover.

The actuator's running status is indicated by three LED's located on the main PCB:

- The green LED (Op) is lit when the valve has been opened.
- The red LED (Cl) is lit when the valve has been closed.

Angle Limitation

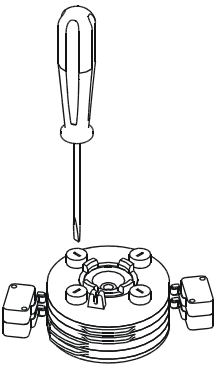

The angle at the drive shaft can be adjusted to between 0° and 90°.

The end position is limited both electrically and mechanically. The electrical limitation can be adjusted by pressing and turning (with a screwdriver) the adjustment screws situated on the white and black cams.

The end position is factory-set to -2° and +92°. As a rule, it is not necessary to alter this value.

Manually Adjusting Valve

⚠ CAUTION

Before manually adjusting the valve, you must first disconnect the power supply!

The valve can be manually adjusted using the manual adjustment wheel and declutch button (see Fig. 1).

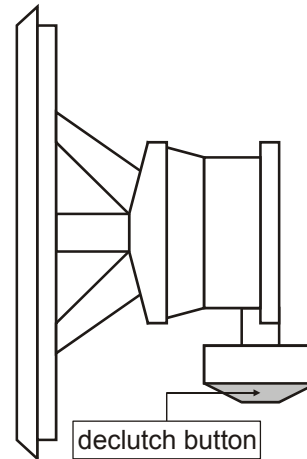

Fig. 1. Manual adjustment wheel and declutch button

The manual safety wheel is disengaged automatically when the motor is running. To use the manual safety wheel, it must therefore first be re-engaged using the declutch button.

Motor and Gear Protection

The actuator motor is protected against overheating by a bimetal temperature monitor.

The motor and gear train are also protected against mechanical overload by a torque limiter switch. The yellow LED (Tq) is lit when the torque limiter has been activated.

Maintenance

The actuators are maintenance-free. They are lubricated for a minimum of 100,000 operations.

If it becomes necessary to renew the grease completely, use a lubricant complying with the following specifications:

- temperature range: -30...+135 °C
- penetration: ASTM 265/295 at 25 °C
- drop point: 180 °C

E.g. ELF Expecta 250, TOTAL Multis EP2, SHELL alvania EP2, MOBIL Mobilux EP2, or ESSO Beacon EP2.

Flow Rate and Pressure Drop

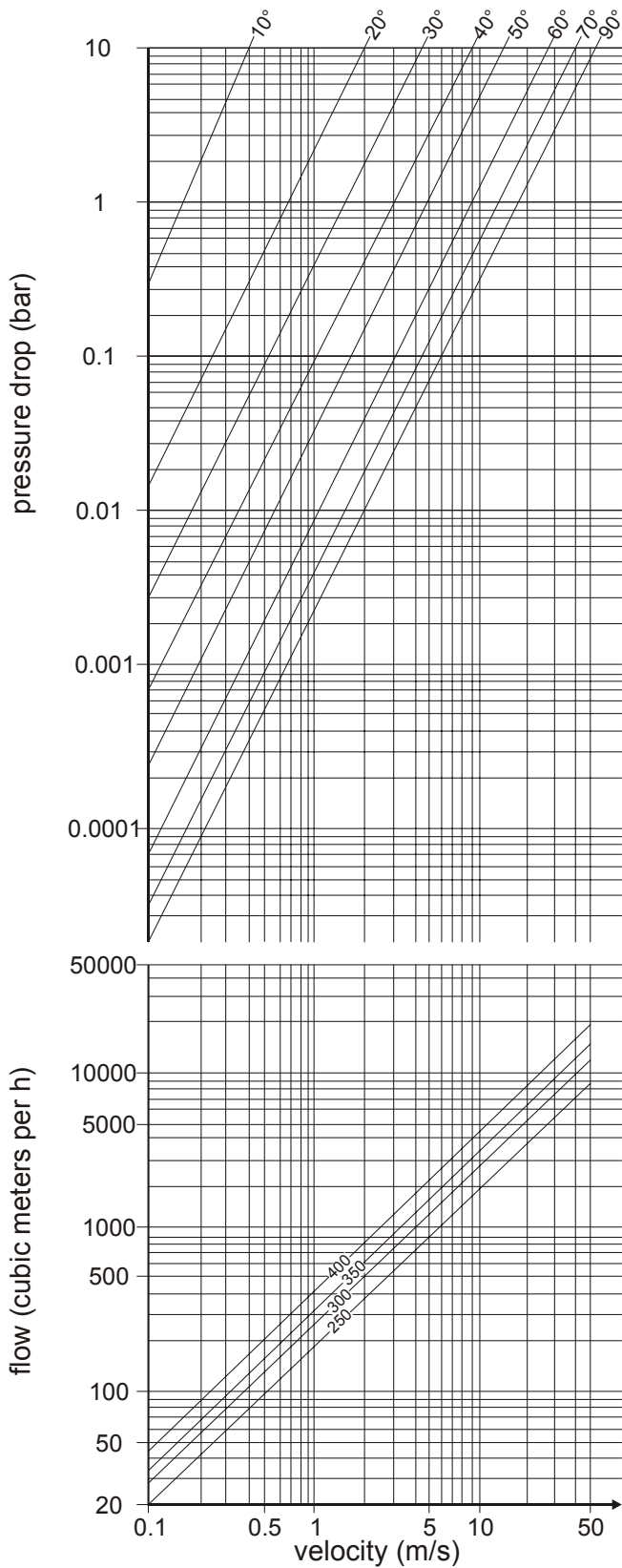

Fig. 2. Flow rate and valve pressure drop

V5422L (Floating Control)

The V5422L series is equipped with a main PCB (see Fig. 3) located (together with the angle indicator) under the cover (see Fig. 4). To access the main PCB, remove the cover.

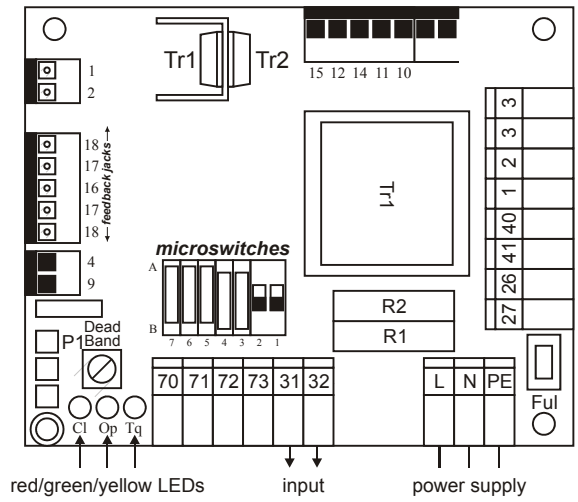

Fig. 3. Main PCB of the V5422L

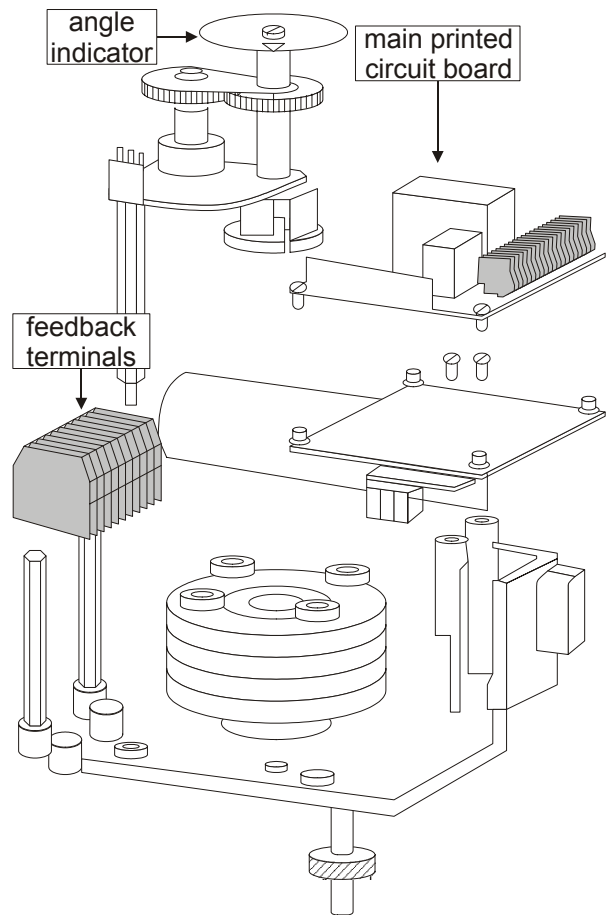

Fig. 4. Explosion view

Input Terminals

An external floating controller controls the actuator of the V5422L. This controller transmits the phase to input 31 (for closing the valve) or to input 32 (for opening the valve). See also Fig. 12.

Feedback Terminals

The V5422L is equipped with two change-over switches (see Fig. 5):

- terminals 20, 21, and 22 (provides a feedback signal that the valve is in the OPEN position) and
- terminals 23, 24, and 25 (provides a feedback signal that the valve is in the CLOSED position).

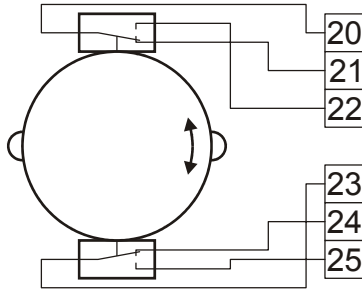

Fig. 5. Feedback terminals

NOTE: These change-over switches must be supplied with power from an independent (external) power source (maximum permissible load: 230 Vac, 16 A).

Adjusting the V5422L for Floating Control

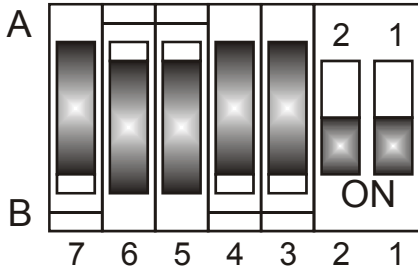

Fig. 6. Default microswitch settings of the V5422L

- To adjust the V5422L for floating control, microswitches 5 and 6 (located on the main PCB; see Fig. 3) must both be set to position "B" (see Fig. 6).

NOTE: In the case of the V5422L, microswitches 1, 2, 3, and 4 have no function/effect.

Adjusting the Direction of Rotation of the V5422L

- To adjust the direction of rotation so that the V5422L closes in the clockwise (right) direction, microswitch 7 must be set to position "A".
- To set the direction of rotation so that the V5422L closes in the counterclockwise (left) direction, microswitch 7 must be set to position "B".

V5422E (Modulating Control)

The V5422E series is equipped with a main PCB (see Fig. 7) located (together with a feedback potentiometer and the angle indicator) under the cover (see Fig. 4). To access the main PCB, remove the cover.

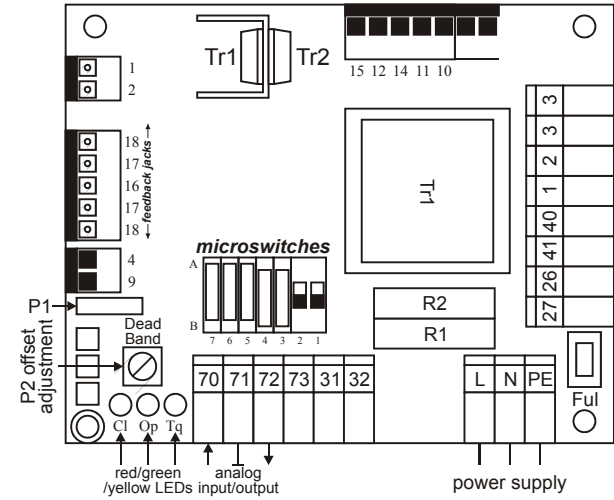

Fig. 7. Main PCB of the V5422E

Adjusting the V5422E for Modulating Control

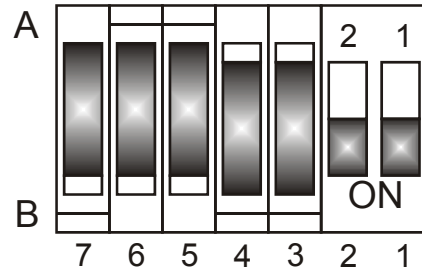

Fig. 8. Default microswitch settings of the V5422E

- To adjust the V5422E for modulating control, microswitches 5 and 6 (located on the main PCB; see Fig. 7) must both be set to position "A" (see Fig. 8).

Adjusting the Direction of Rotation of the V5422E

- To adjust the direction of rotation so that the V5422E closes in the clockwise (right) direction, microswitch 7 must be set to position "A".
- To set the direction of rotation so that the V5422E closes in the counterclockwise (left) direction, microswitch 7 must be set to position "B".

See also section "Reversing Direction of Rotation of the V5422E".

Adjusting the Input Signal Range of the V5422E

The input signal range (0/2...10 V or 0/4...20 mA) and the corresponding output signal are set using microswitches 1, 2, 3, and 4 (see Table 2).

Table 2. Adjusting the input signal range (V5422E)

Input signal	output signal	microswitch positions						
		1	2	3	4	5	6	7*
0...10 V	0...10 V	B	B	B	B	A	A	A/B
2...10 V	2...10 V	B	B	B	A	A	A	A/B
4...20 mA	4...20 mA	A	A	A	A	A	A	A/B
0...20 mA	0...20 mA	A	A	A	B	A	A	A/B
0...10 V	0...20 mA	B	B	A	B	A	A	A/B
2...10 V	4...20 mA	B	B	A	A	A	A	A/B
4...20 mA	2...10 V	A	A	B	A	A	A	A/B
0...20 mA	0...10 V	A	A	B	B	A	A	A/B

*Depends upon desired direction of rotation.

Terminals for Input/Output Signals

An external modulating controller controls the actuator of the V5422E by means of an analog signal provided at terminal 70/71. An analog output signal for position indication is provided at terminal 71/72.

Adjusting the Input/Output Signal Offset

The offset of modulating actuators is adjusted at the factory and should not be changed. If you wish to change the offset (using offset potentiometer P2; see Fig. 7), note that an excessively small offset will result in oscillation of the actuator.

Reversing Direction of Rotation of the V5422E

In the case of the V5422E, it is possible to reverse the direction of rotation of the valve by adjusting the feedback signals. The feedback signals are adjusted by resetting the microswitches and replugging the feedback potentiometer's cables. To do this, proceed as follows:

1. Turn the power off.
2. Reset the microswitches as shown in Table 2, but with microswitch 7 in position B.
3. Replug the feedback potentiometer's cables as shown in Fig. 9.

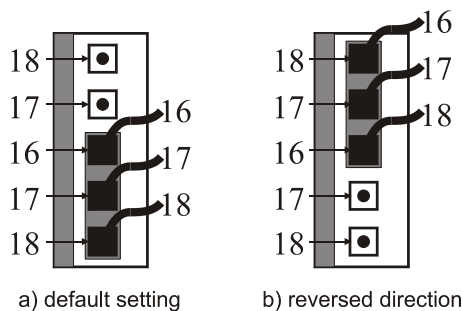

Fig. 9. Replugging the feedback potentiometer's cables

4. Apply the desired control signal (10 V or 20 mA, as the case may be) for the closing position.
5. Turn the power back on.
6. Using a small screwdriver, adjust the potentiometer P1 (located on the main PCB; see Fig. 7) until the valve closes completely.

Valve Mounting

Install the actuated valve in the pipe according the following steps (see also Fig. 10).

1. Spread the valve's flanges to facilitate installation. The valve's disc must be partially open.
2. Set all stay-bolts while keeping the valve's disc slightly open and without tightening the nuts.
3. Open the valve's disc completely. Ensure that the piping is aligned. Tighten diagonally opposite the nuts until the flanges are in contact with the body of the valve. Never use gaskets or grease. Never weld the flanges after the valve has been installed.

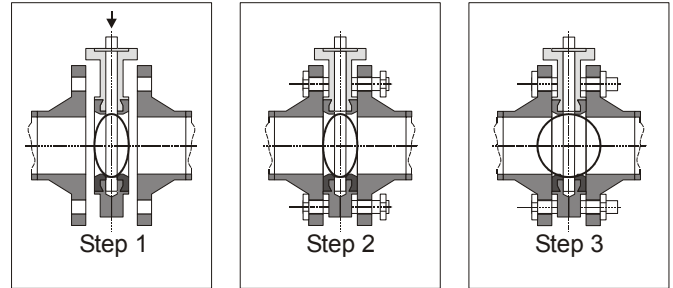

Fig. 10. Installing the valve

Bolting

Table 3 lists the number of bolts and nuts required for mounting. The number is dependent upon the size (DN).

Table 3. Bolts and nuts required for installation

DN	PN10	
	bolts (M x length)	number
250	M20x150	12
300	M20x160	12
350	M20x160	16
400	M24x190	16

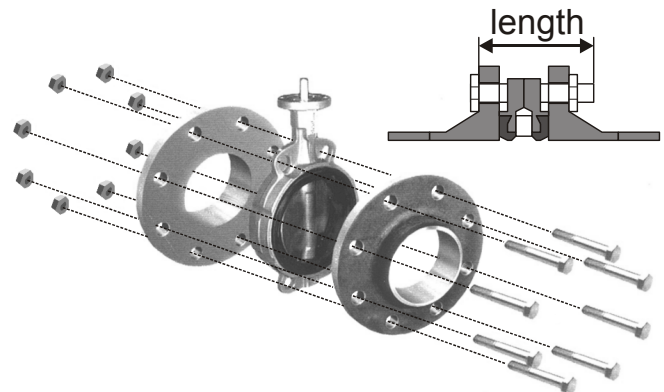

Fig. 11. Bolting

WIRING DIAGRAMS

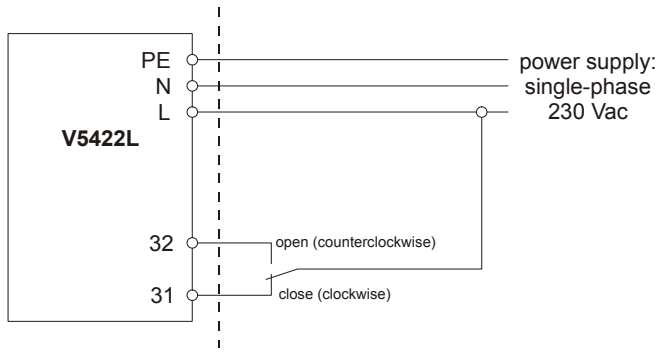

Fig. 12. Floating Control (V5422L)

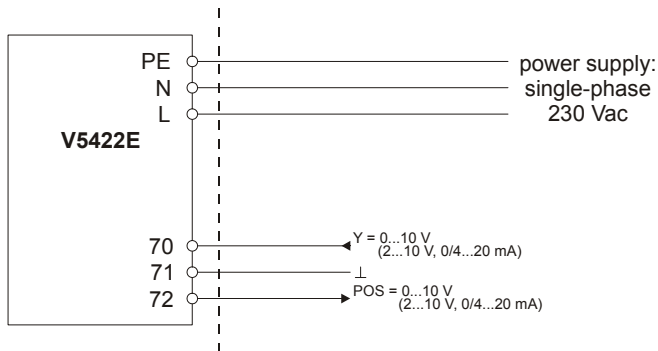

Fig. 13. Modulating Control (V5422E)

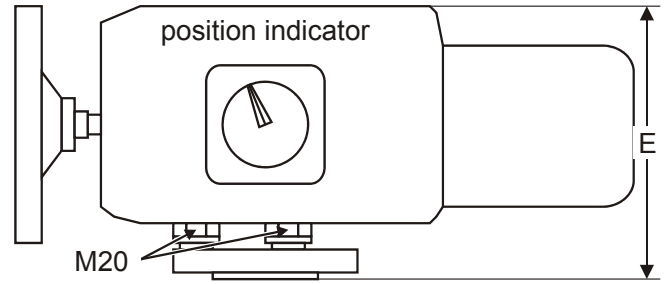

Fig. 14. Actuated butterfly valve (side view)

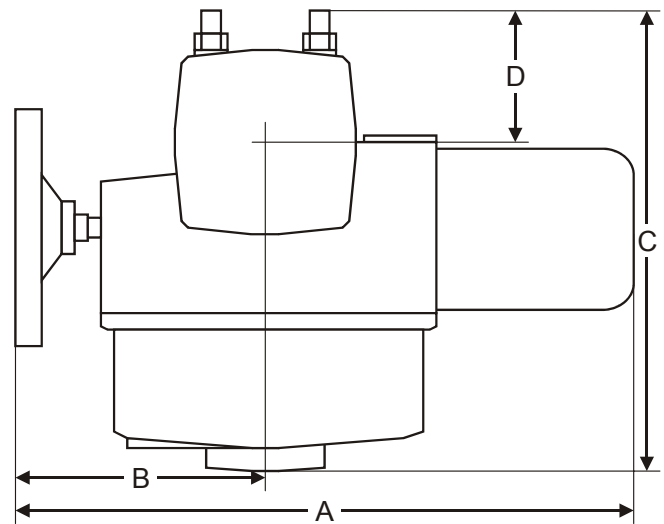

Fig. 15. Actuated butterfly valve (top view)

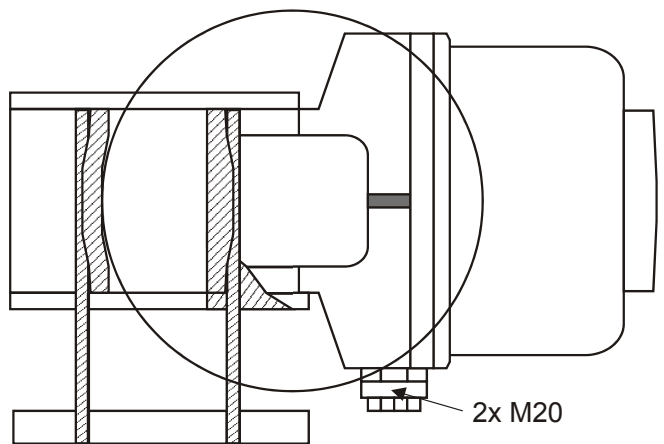

Fig. 16. Actuated butterfly valve (cross-sectional view)

DIMENSIONS

Actuator Dimensions and Weight

Table 4. Actuator dimensions and weight

valve size (DN)	actuator dimensions (mm)					weight (kg)
	A	B	C	D	E	
250	509	169	315	89	177	17
300	509	169	315	89	177	17
350	509	169	315	89	177	17
400	564	172	417	133	167	30

Valve Dimensions and Weight

Table 5. Valve dimensions and weight

valve size (DN)	valve dimensions (mm)					weight (kg)
	A	B	C	D	H	
250	280	196	68	324	243.5	22.2
300	315	232	78	378	292.5	30.8
350	330	257	78	425	329.5	41.5
400	365	292	102	475	375.5	57.2

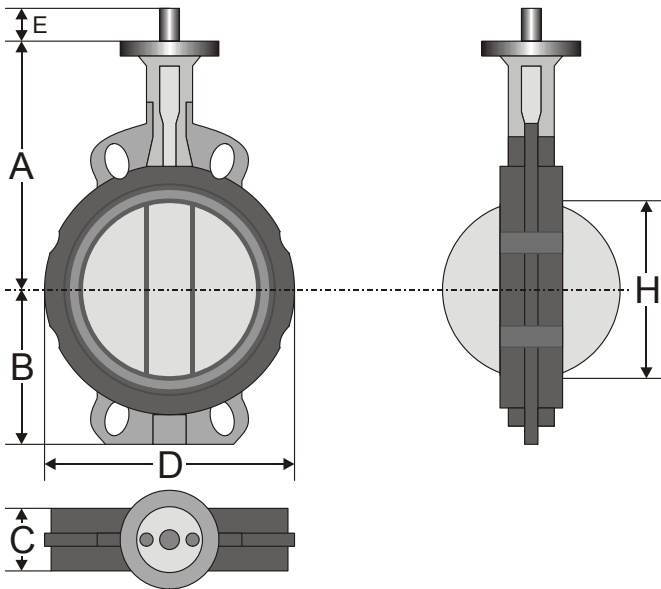

Fig. 17. Valve dimensions

Manufactured for and on behalf of the Environmental and Combustion Controls Division of Honeywell Technologies Sàrl, Ecublens, Route du Bois 37, Switzerland by its Authorized Representative:

Automation and Control Solutions

Honeywell GmbH
Böblinger Straße 17
D-71101 Schönaich
Phone: (49) 7031 63701
Fax: (49) 7031 637493
<http://europe.hbc.honeywell.com>

Subject to change without notice. Printed in Germany

EN0B-0319GE51 R0107

DIN EN ISO
9001/14001