

VFF Series IMMERSION TEMPERATURE SENSOR

PRODUCT DATA



GENERAL

The VFF Immersion Temperature Sensor is used in heating, cooling or domestic hot water applications requiring fast response temperature measurement.

TYPES

| OS no. | Description | Sensing range |
|--------------|--------------------------------------------------|---------------------------------|
| VFF20-75P65 | sensor element: NTC20kΩ sensor length: 75 mm | -20...+140 °C (-4...+284 °F) |
| VFF20-220P65 | sensor element: NTC20kΩ sensor length: 220 mm | |
| VFF20-300P65 | sensor element: NTC20kΩ sensor length: 300mm | |
| VFF00-75P65 | sensor element: PT1000 sensor length: 75 mm | |
| VFF00-220P65 | sensor element: PT1000 sensor length: 220 mm | |

FEATURES

- Fast response time
- Operating range of -20...+140 °C
- Easy installation
- Adjustable well length
- Stainless steel body material

SPECIFICATIONS

Nominal value

| | |
|-----------------|----------------|
| VFF20 (NTC20kΩ) | 20 kΩ at 25 °C |
| VFF00 (PT1000) | 1000 Ω at 0 °C |

Accuracy

| | |
|-----------------|-------------------------------------------|
| VFF20 (NTC20kΩ) | ±0.2 °C at 25 °C (77 °F) |
| VFF00 (PT1000) | IEC751 Class B ±0.3 °C at 0 °C (32 °F) |

Sensitivity

| | |
|-----------------|--------------------------------------|
| VFF20 (NTC20kΩ) | ≈ -934.5 Ω / K at 25 °C (non-linear) |
| VFF00 (PT1000) | ≈ 3.85 Ω / K |

Response time

$\tau_{63} < 2.5$ seconds

Well

Pressure rating PN16 (nominal)

Max. flow rate in water at 16 bar and < 140°C

| | |
|---------------|---------|
| 75 mm length | 8 m/s |
| 220 mm length | 1.5 m/s |
| 300 mm length | 0.5 m/s |

Medium

Mineral and synthetic oil, glycol-water mixture, domestic hot water, swimming pool water

Material

Stainless steel, 1.4571

Dimensions

ø 4 mm, length ~ 75/220/300 mm

Outlet size

R1/2"

Tightening torque

10 ±2 Nm, 13-mm wrench

Cable

Length 2.5 m

Protection class

IP 65

ELECTRICAL CONNECTION

The wiring of the temperature sensor must be in accordance with the overall wiring circuit diagram. The terminals are not polarized; thus, even if the wires are connected in reverse, no malfunction will occur.

DIMENSIONS

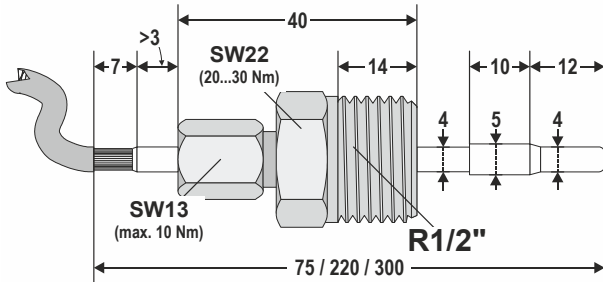

Fig. 1. Dimensions (in mm)

MOUNTING

The temperature sensor should be screwed into place with a maximum torque of 10 ± 2 Nm. The temperature sensor should be inserted so that the tip is well past the laminar flow at the inner wall of the pipe (minimum 25 mm) – ideally at the middle of the pipe, though this may result in excessive mechanical stress of the well in the event of high flow rates. See also Fig. 2 through Fig. 4.

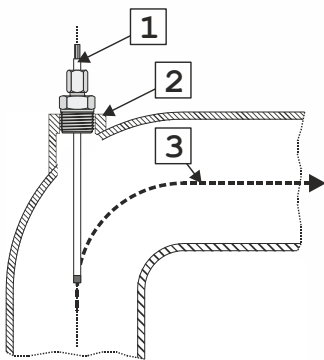

Fig. 2. \leq DN50, elbow pipe

1. Temperature sensor (max. torque = 10 ± 2 Nm)
2. Weld junction with the screw thread
3. Direction of flow

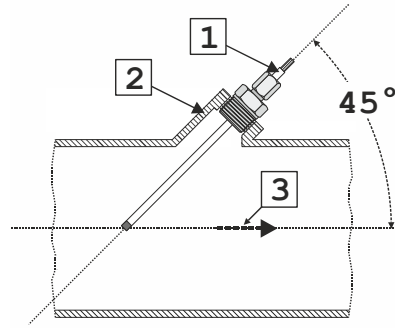

Fig. 3. \leq DN50, straight pipe

1. Temperature sensor (max. torque = 10 ± 2 Nm)
2. Weld junction with the screw thread
3. Direction of flow

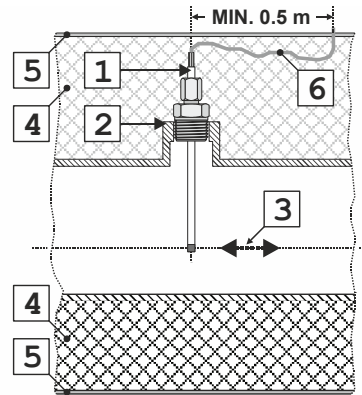

Fig. 4. DN65...150, coldwater application

1. Temperature sensor (max. torque = 10 ± 2 Nm)
2. Weld junction with the screw thread
3. Flow in either direction
4. Insulation material
5. Water vapor barrier
6. Minimum 0.5 meter through insulation material before exit.

Honeywell

Manufactured for and on behalf of the Environmental & Energy Solutions Division of Honeywell Technologies Sàrl, Rolle, Z.A. La Pièce 16, Switzerland by its Authorized Representative:

Automation and Control Solutions

Honeywell GmbH
 Böblinger Strasse 17
 71101 Schönaich, Germany
 Phone +49 (0) 7031 637 01
 Fax +49 (0) 7031 637 740
<http://ecc.emea.honeywell.com>

EN0B-0721GE51 R1016C

Subject to change without notice