

Switching actuator (Relay) RL 512/23

5WG1 512-4AB23

Product and Application Description



The RL 512/23 Switching actuator (relay) is a KNX device with one switching output. The device is installed in an AP 118 Control Module Box or an AP 641 Room Control Box. The bus is connected via a bus terminal block. The actuator electronics are supplied via the bus voltage.

The RL 512/23 can switch resistive loads (e.g. electrical heaters, incandescent lamps, high voltage halogen lamps), inductive loads (e.g. motor, low voltage halogen lamps with intermediate conventional transformers), or capacitive loads (e.g. low voltage halogen lamps with intermediate electronic transformers).

The actuator output may be configured independently to provide switching, manual override, forced control, logical gate, and status reporting. Furthermore, if required, time-limited switching instead of permanent switching on can be enabled for each channel via an optional "Night mode" object (e.g. for lighting while cleaning), if need be with a warning before switching off by multiple switching the output on and off (flashing).

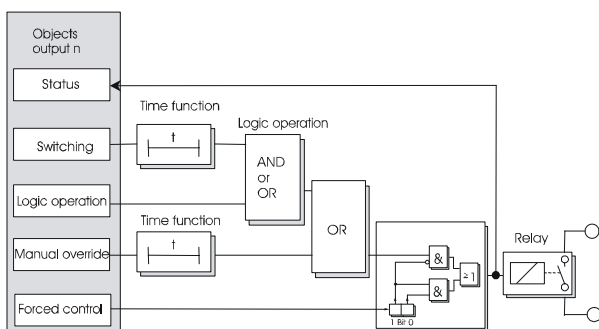

Amongst others, the application program includes optional a switching cycle and operating hours count with threshold monitoring for each output and an integrated 8-bit scene control, in which the output can be incorporated into up to 8 scenes.

Each output of the actuator may be set to one of the following operating modes:

- Normal operation
- Timer operation

Behavior at bus voltage failure / recovery

On bus voltage failure the current switching status value is saved for restoration on bus voltage recovery.

On bus voltage recovery the configured actions are executed and, if applicable, new status values are reported.

Building site function

The building site function provided ex-factory enables switching the building site lighting on and off via bus wall switches and actuators, even if these devices have not yet been commissioned with ETS.

Building site function

The building site function provided ex-factory enables switching the building site lighting on and off via bus wall switches and actuators, even if these devices have not yet been commissioned with ETS.

Behavior on unloading the application program

When the application program is unloaded with ETS the device does not function.

Resetting the device to ex-factory settings

When the programming button is pressed for more than 20 seconds the device is reset to the ex-factory settings. All configuration settings are lost. The building site function is re-activated.

The device is configured and commissioned with the ETS (Engineering Tool Software) version ETS3 v3.0f or later.

Application programs

The RL 512/23 Switching actuator (relay) needs the application program "07 B0 A1 Switch actuator 982D01".

Example of operation

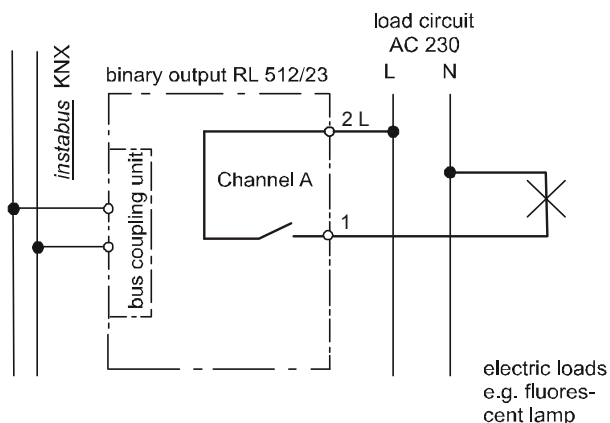

figure 1: Example of operation

Installation notes

- The device is intended for installation in an AP 118 Control Module Box or an AP 641 Room Control Box.



DANGER

- The device must be mounted and commissioned by an authorized electrician.
- A safety disconnection of the device must be possible.
- The device must not be opened.
- For planning and construction of electric installations, the relevant guidelines, regulations and standards of the respective country are to be considered.
- **When looping through the L-conductor, take care that the maximum permissible terminal load current of 16A is not exceeded!**

Technical Data

Power supply

- via the bus line
- KNX bus voltage: DC 24V (DC 21...30V) via KNX/EIB bus line
- KNX bus current: < 10 mA

Outputs

- switching output, potential-free relay contacts:
 - rated voltage: AC 230/440 V, 50/60 Hz
 - rated current:
 - 16 AX (200 µF) to DIN EN 60669-1,
 - 20 A in AC1 mode (cos φ = 0.8) and 16 A in AC3 mode (cos φ = 0.45) as to DIN EN 60947-4-1,
 - DC switching capacity: 16A at 24V DC
 - min. switching capacity: 100 mA at 12V AC,
 - min. switching capacity: 100 mA at 24V AC,
 - Incandescent lamp load: max. 3,680 W
 - LV halogen lamps, inductive transformer: 2,000 W
 - LV halogen lamps, electronic transformer: 2,500 W
 - Fluorescent lamps T5 / T8, uncompensated: 3680 W
 - Fluorescent lamps T5 / T8, parallel compensated: 2500 W / 200 µF
 - Fluorescent lamps T5 / T8, DUO-configuration: 3680 W
 - Number of OSRAM ballasts QTI 1x28/54W: 56 pcs.
 - Number of OSRAM ballasts QTI 1x 18/24/36 W: 31 pcs.
 - Number of OSRAM ballasts QTI 1x 58 W: 21 pcs.
 - Number of OSRAM ballasts QTI 2 x 18/24/58 W; 3 x 18 W; 4 x 18 W: 9 pcs.
 - Dulux lamp, uncompensated: 3680 W
 - Dulux lamp, parallel compensated: 3000 W
 - Mech. lifetime: > 1,000,000 switching cycles
 - Electr. lifetime: > 100,000 at AC1, > 30,000 at AC3
 - Max. relay position changes per minute: 60

Control elements

- 1 learning button:
 - for switching between normal operating mode and addressing mode

Display elements

- 1 red LED:
 - for monitoring bus voltage and for displaying normal mode/addressing mode

Switching actuator (Relay) RL 512/23

5WG1 512-4AB23

Connections

- Bus line : Bus connection pins for connection of the screwless bus terminal block (red-black) 0.6...0.8 mm Ø single core, strip insulation 5mm
- Load circuit: screwless terminals 0.5 ... 2.5mm² single-core, stranded or multi-core, untreated, strip insulation 9 ... 10mm

Physical specifications

- housing: plastic
- dimensions (L x W x D): 86,5 x 47,8 x 36,2 mm
- weight: approx. 70 g
- fire load: approx. 1200 kJ
- Installation: Mounting location for RS / RL module in AP 118 Control Module Box (5WG1 118-4AB01) or AP 641 Room Control Box (5WG1 641-3AB01)
- Thermal dissipation loss:
 - Device: 0,15 W (= min. total thermal dissipation loss)
 - per output: $0,004 * (I_{eff})^2$ [W]
 - min. total thermal dissipation loss: 0,15 W (load: 0A)
 - max. total thermal dissipation loss: 1,17 W (load: 16A)

Electrical safety

- Degree of pollution (according to IEC 60664-1): 2
- Type of protection (according to EN 60529): IP 20
- Overvoltage category (according to IEC 60664-1): III
- Bus: safety extra low voltage SELV DC 24 V
- Relay with μ - contact
- Device complies with: EN 50428

Electromagnetic compatibility

complies with EN 50428

Environmental conditions

- Climatic conditions: EN 50090-2-2
- Ambient operating temperature: - 5 ... + 45 °C
- Storage temperature: - 25 ... + 70 °C
- Relative humidity (not condensing): 5 % ... 93 %

Reliability

- Failure rate: 249 fit at 40°C

Markings

KNX, EIB

CE norm

- complies with the EMC regulations (residential and functional buildings), low voltage regulations

Location / Function of the Display and Operating Elements

figure 2: Location / function of the display and operating elements

- A1 LED for indicating normal operating mode (LED off) or addressing mode (LED on); returns to normal operating mode automatically after receiving the physical address
- A2 Learning button for switching between normal operating mode and addressing mode and for receiving the physical address
- A3 Bus connection pins of the module for connection of the bus terminal block for single core conductors with 0,6...0,8 mm Ø
- A4 Type label (with space for physical address of the actuator)
- A5 Terminal Channel A
- A6 Distance plate
- A7 Terminal L
- A8 Identification number of the device

Mounting and Connecting

- B2 RL module
- B3 Type label
- B4 Mounting location for RS / RL module in AP 118 Control Module Box or AP 641 Room Control Box
- B8 Learning button
- B9 LED for indicating normal operating or addressing mode
- B10 Bus connection pins of the connection module for respective bus terminal block of the internal bus wire
- B11 Insertion point for bus terminal
- B12 Bus connection block
- B13 Hinge joint for mounting hinge of the RL module
- B14 Terminals

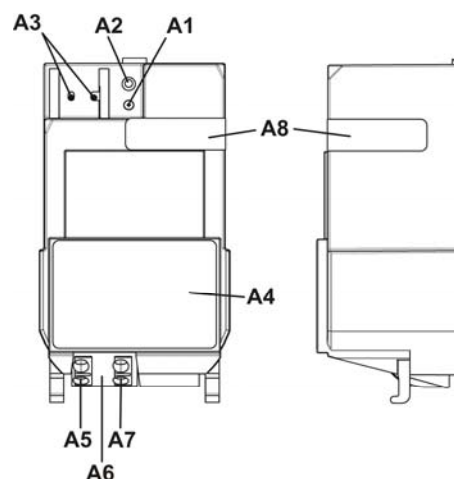
• Mounting of an RL module:

- Remove the lid of the AP 118 Control Module Box respectively of the AP 641 Room Control Box.
- AP 641: Remove the SELV (Class 2) cover
- Insert the RL module (B2) into the hinge (B13) of the mounting location (B4). The terminals (B14) point away from the insertion point for the bus terminal (B11). The type label (B3) is on top.
- Swivel the RL module (B2) down until it audibly snaps into the mounting location (B4).
- Insert the bus terminal (B12) of the mounting location (B4) onto the bus connection pins (B10) of the RL module (B2).
- For assignment of the Physical Address press the learning button (B8) for a maximum of 2 seconds. The addressing mode is indicated when the LED is on (B9). It returns to normal operating mode (LED Off) automatically after receiving the physical address.
- AP641: Insert the SELV (Class 2) cover again.
- Mount the lid again.

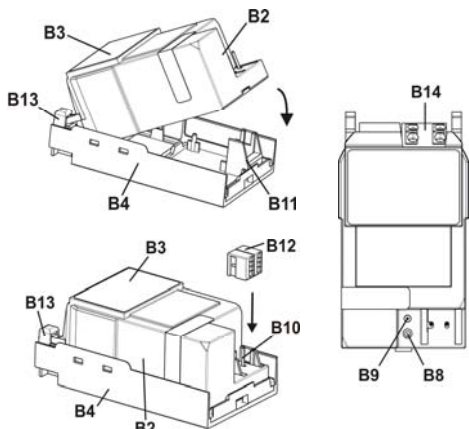

figure 3: Mounting of an RL module

• Dismounting an RL module:

- Remove the lid of the AP 118 Control Module Box respectively of the AP 641 Room Control Box.
- AP 641: Remove the SELV (Class 2) cover
- Remove the wiring from the terminals (B14).
- Remove the bus terminal (B12).
- To remove the RL module (B2), insert a screw driver between the module and the mounting location on the bus terminal side and push it up to release it from the snap-in hooks.
- Swivel the RL module (B2) up, pull it down out of the hinge (B13) and remove it from the mounting location (B4).
- AP641: Insert the SELV (Class 2) cover again.
- Mount the lid again.

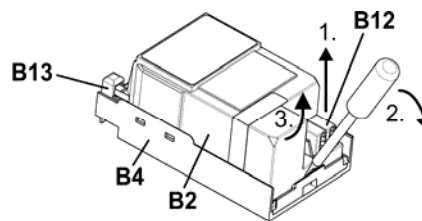

figure 4: Dismounting an RL module

Switching actuator (Relay) RL 512/23

SWG1 512-4AB23

ConnectingSlipping off/on bus connection blocks

It consists of two components (C2.1 and C2.2) with four terminal contacts each. Take care not to damage the two test sockets (C2.3) by accidentally connecting them to the bus cable or with the screw driver (e.g. when attempting to unplug the bus connection block).

Slipping off bus connection blocks

- Carefully put the screw driver to the wire insertion slit of the bus connection block's grey component (C2.2) and
- pull the bus connection block (C2) from the module.

Note

Don't try to remove the bus connection block from the bottom side. There is a risk of shorting-out the device!

Slipping on bus connection blocks

- Slip the bus connection block (C2) onto the guide slot of the module and
- press the bus connection block (C2) down to the stop.

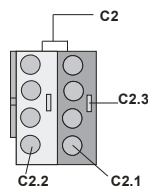

figure 5: Slipping off / on bus connection blocks

Connecting bus cables

- The bus connection block (D2) can be used with single core conductors \varnothing 0.6...0.8 mm.
- Remove approx. 5 mm of insulation from the conductor (D1) and plug it into the bus connection block (D2) (red = +, grey = -)

Disconnecting bus cables

- Unplug the bus connection block (D2) and remove the bus cable conductor (D1) while simultaneously wiggling it.

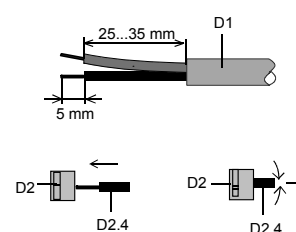

figure 6: Connecting / disconnecting bus cables

Connecting/disconnecting mains and load circuit:Connect wires

- The load circuits are connected via screwless plug-in terminals (E1).
- Remove approx. 9...10 mm of insulation from the wire (E 1.1) and plug it into the terminal (E1).
- The terminals are designed for connection of two wires allowing to loop through the terminal block.

Note:

The maximum permissible terminal load current is 16A.

Remove wires

- Press the terminal interlocking of the terminal (F1) with a screw-driver and remove the wire (F2) from the terminal (F1).

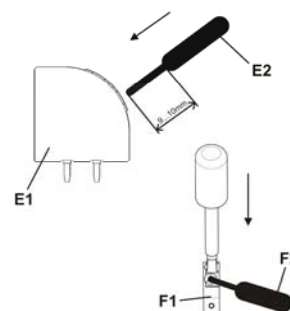
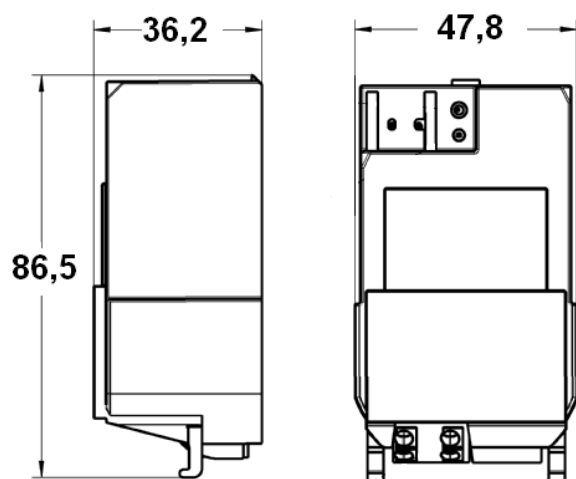

figure 7: Connecting /disconnecting mains and load circuit

Dimension Drawing

Dimensions in mm



Space for notes

General Notes

- The operating instructions must be handed over to the client.
- Any faulty device is to be sent together with a return delivery note of the local Siemens office.
- For any technical questions, please consult:
 - ☎ +49 (911) 895-7222
 - ☎ +49 (911) 895-7223
 - ✉ support.automation@siemens.com
 - www.siemens.com/automation/support-request