

Datasheet

Subject to technical alteration
Issue date: 16.09.2015



Application

The **thanos** touch screen room operating unit has integrated temperature and optional humidity sensors for operation of HVAC, lighting and blind control. Integrated quality optics, the Thanos is ideal for high end design applications. Programmable operating function keys allowing flexibility for custom room designs.

Functions

- Control of automatic HVAC applications by simple touch
- Integrated temperature detection
- Optionally with integrated humidity detection
- Touch surface made of glass
- Intuitive operation
- Operational functions: Light on/off/dimming, set point adjustment, blinds up/down/adjusting, fan stages, presence ...
- Display: Room temperature, set point, operating mode, fan stage, presence, failure, date and time ...
- Display/Buttons: 3,5" TFT, 320x640 pixel, 262.144 colours, capacitive touch technology, large thanos types additionally with up to 8 touch buttons
- Function clip: Anodised aluminium, with touch sensor, functions can be free parameterised (occupied/unoccupied, light on/off ...)
- Available optionally with an integrated LON – EnOcean gateway

Types Available

thanos / thanos rH

S black	black, 3,5" TFT, power supply 24 V ~/24 V =
SQ black	black, 3,5" TFT, cross version, power supply 24 V ~/24 V =
L black	black, 3,5" TFT, additional panel with 8 touch sensor buttons, power supply 24 V ~/24 V =
LQ black	black, 3,5" TFT, additional panel with 8 touch sensor buttons, cross version, power supply 24 V ~/24 V =
S white	white, 3,5" TFT, power supply 24 V ~/24 V =
SQ white	white, 3,5" TFT, cross version, power supply 24 V ~/24 V =
L white	white, 3,5" TFT, additional panel with 8 touch sensor buttons, power supply 24 V ~/24 V =
LQ white	white, 3,5" TFT, additional panel with 8 touch sensor buttons, cross version, power supply 24 V ~/24 V =



Security Advice – Caution



The installation and assembly of electrical equipment should only be performed by authorized personnel.

The product should only be used for the intended application. Unauthorised modifications are prohibited! The product must not be used in relation with any equipment that in case of a failure may threaten, directly or indirectly, human health or life or result in danger to human beings, animals or assets. Ensure all power is disconnected before installing. Do not connect to live/operating equipment.

Please comply with

- Local laws, health & safety regulations, technical standards and regulations
- Condition of the device at the time of installation, to ensure safe installation
- This data sheet and installation manual

Notes on Disposal



As a component of a large-scale fixed installation, Thermokon products are intended to be used permanently as part of a building or a structure at a pre-defined and dedicated location, hence the Waste Electrical and Electronic Act (WEEE) is not applicable. However, most of the products may contain valuable materials that should be recycled and not disposed of as domestic waste. Please note the relevant regulations for local disposal.

Technical Data

Measuring values		temperature, humidity (optional)
Network technology		LON FT (free topology)
Power supply		15..24 V = ($\pm 10\%$) or 24 V ~ ($\pm 10\%$)
Power consumption		typ. 2,0 W (24 V =) 4,0 VA (24 V ~)
Measuring range temperature		0..50 °C
Measuring range humidity		0..100% rH non-condensing
Accuracy temperature		$\pm 0,5$ K (typ. at 21 °C)
Accuracy humidity		$\pm 3\%$ between 20..80% rH (typ. at 21 °C)
Inputs	digital	4, individual configuration for window contact, dew point guard, key card switch, room frequency, alarm, event
Control functions		presence frequency, light ON/OFF/DIM, setup scenarios, blinds UP/DOWN/SET, fan stages, setpoint
Clip		anodized aluminium
Functions		configurable via software configuration (present/absent, light ON/OFF, ...)
No. of buttons	type L/LQ	8 capacitive touch sensor buttons
Labelling	type L/LQ	flexible insert (for up to 8 touch buttons below/beside clip)
Display		3,5" TFT, 320x240 Pixel, 262.144 colours, capacitive touch technology, showing room temperature, set point, operation mode, fan stage, occupancy, alarm, date and time
Colour		white or black
Enclosure		PC and glass
Protection		IP20 according to EN 60529
Connection electrical		terminal block, max. 1,5 mm ²
Ambient condition		0..+50 °C, max. 70% rH non-condensing
Weight	type S/SQ type L/LQ	300 g 400 g
Mounting		flush mounted with standard EU box ($\varnothing=55$ mm)
Notes		for further information please refer to software description thanos at www.thermokon.com

Mounting Advices

The device is designed for mounting on a flush box.

The bus cable is connected to the device by a screw terminal. For pre-wiring, the terminal screw can be drawn from the device. Due to the extended retaining capacity for the cabling, the use of deep installation boxes is recommended. It is important to ensure adequate heat dissipation. The fastening of the wall unit can be done by the screws of the installation box, (max. torque of screws 0,8 Nm).

Installation has to be done at representative places for the room temperature to avoid a falsification of the measuring result. Solar radiation and draught should be avoided. The end of the installation tube in the flush box must be sealed to avoid any draught in the tube falsifying the measuring result.

Please refer to general remarks in our "INFO THK".

Please note, that the adjusted brightness value of the display and the button area can have an effect on the temperature measurement due to occurring self-heating. thanos has a special functionality to keep these effects as low as possible.

The final values are available after approx. 100 minutes. When installing thanos for the first time, an offset calibration should be done earliest 100 minutes after installation.

Connection Plan

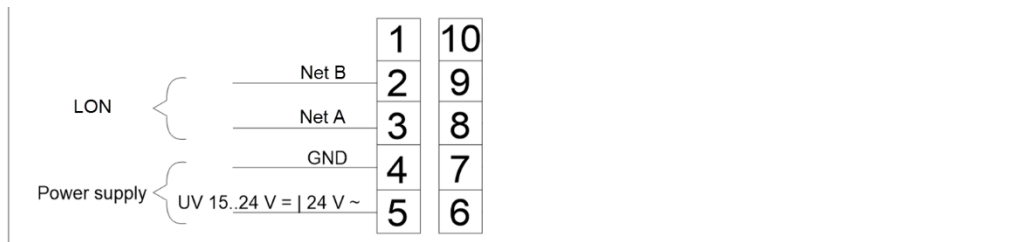

Mounting Device

1. Place wall unit.
2. Mount wall unit with countersunk screws.
3. Insert operating unit carefully into the wall unit and click it in.

thanos S / SQ

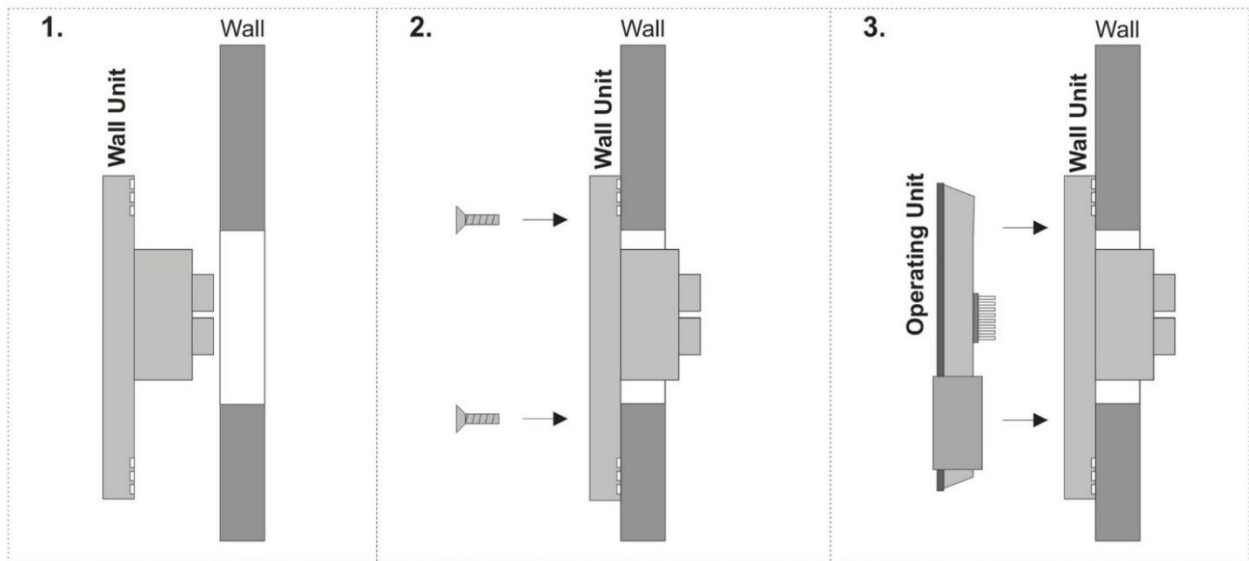

thanos S / SQ

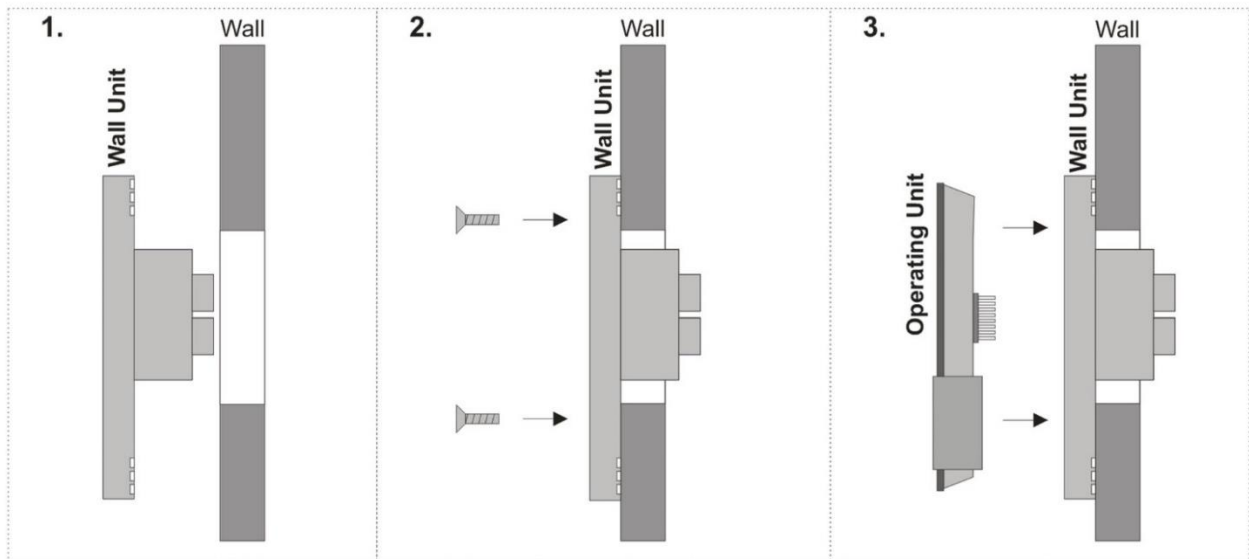

Remove Operating Unit

1. Insert extraction tools into the available slots.
2. Take the operating unit at the edges and remove it carefully from the wall-unit

thanos S / SQ

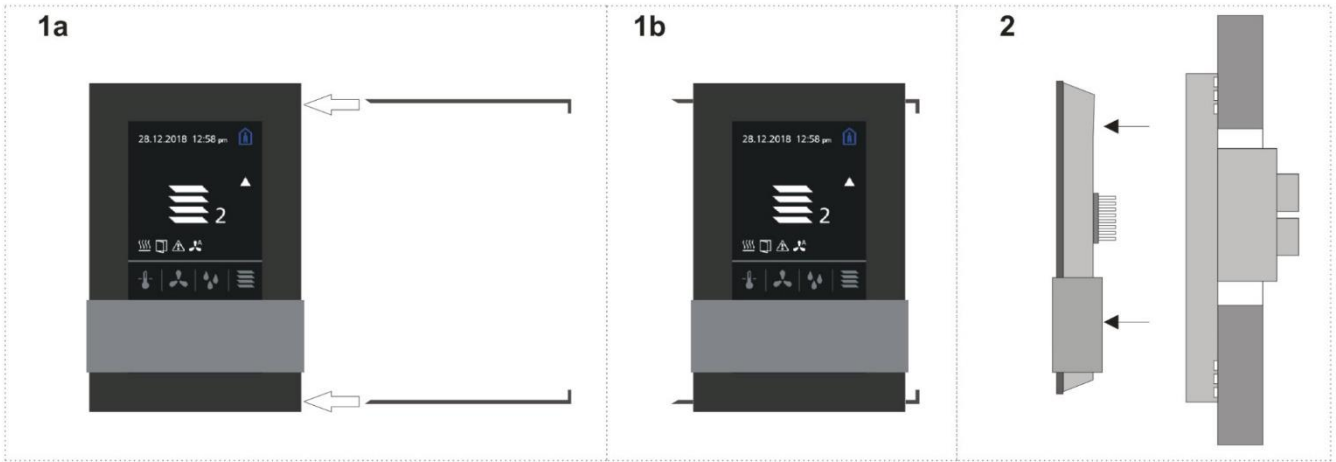

thanos L / LQ

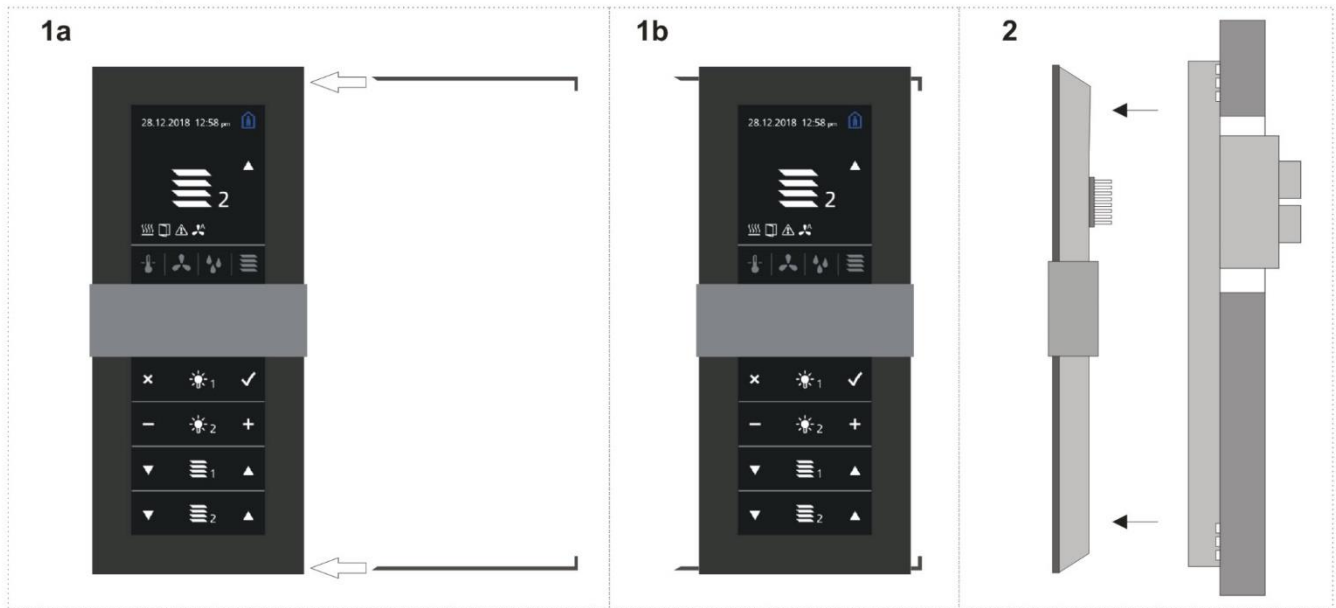

Insert label sheet (L & LQ)

To insert the label sheet (thanos L & LQ), follow these steps:

3. Print the label sheet.
4. Remove the front panel.
5. Put the two unlocking tools, as shown below, and slide it along the slot.
6. Slide the foil carefully down between the glass and light guide.

Each device is delivered including a blank label sheet, which can be printed with a standard laser or inkjet printer. The template-file is on the software CD, which is enclosed as well.

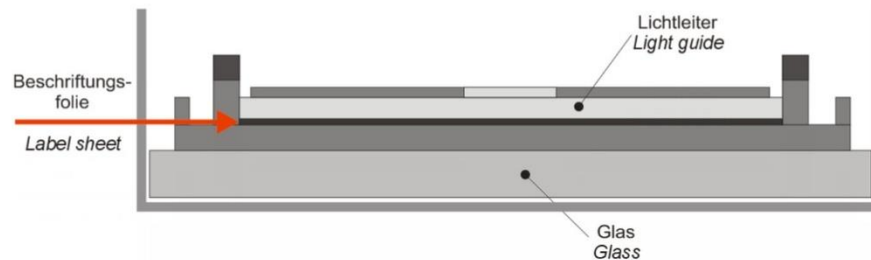
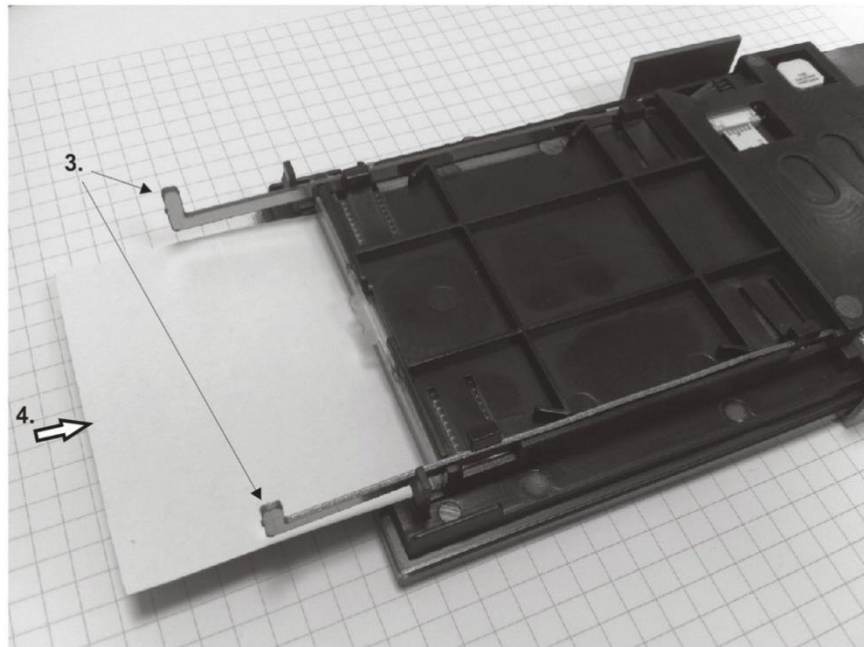

Dimensions (mm)

thanos S / SQ

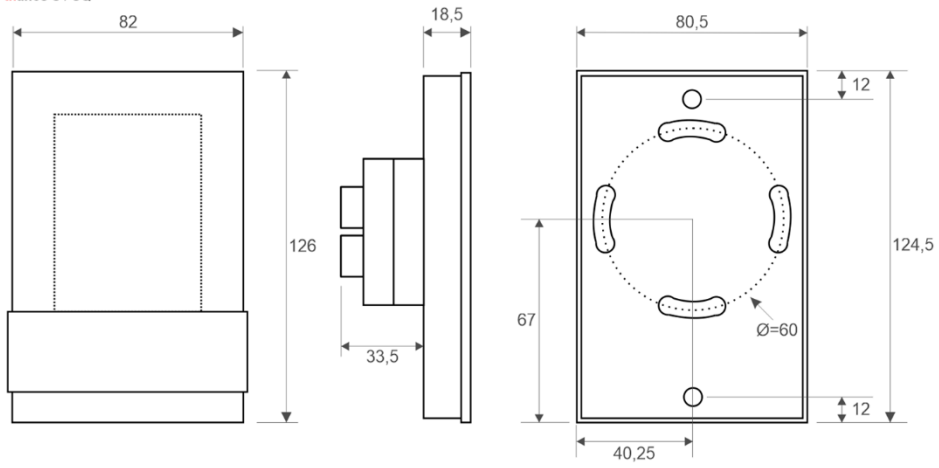

thanos L / LQ

