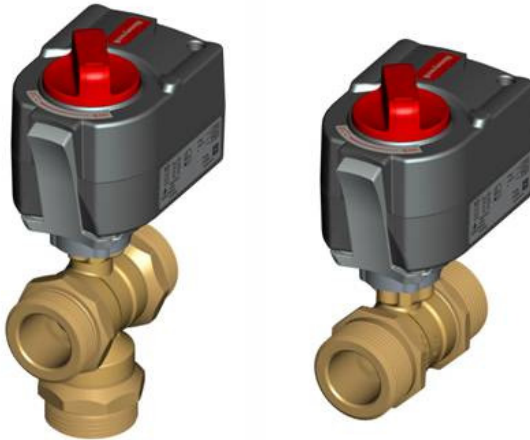


VBGx-xx-xx Externally Threaded Control Ball Valves

PN25 (DN15 TO DN32)

SPECIFICATION DATA



APPLICATION

The VBG2 2-Way and VBG3 3-Way Control Ball Valves control hot and chilled water with glycol solutions up to 50% according to VDI2035 in heating, ventilating, and air conditioning (HVAC) systems to provide two-position or modulating functions.

Features

- Sizes from DN15 to DN32 with external (male) BSPP (G) connections 1" to 2".
- Equal percentage flow characteristic.
- Compatible MVN Rotary Valve Actuators: 2-position, floating, modulating, non-spring return.
- Removable manual operating handle to control valve during installation or in the event of power failure.
- Actuator can be mounted on the valve in any of four orientations.
- Wide range of k_{vs} choices from 0.25 to 25.
- Nickel-chrome plated brass ball.
- Valve installs in a globe valve "T" pattern, no extra elbows or piping required.
- Mixing or diverting control for 3-way valves.
- Leakage rate A, air bubble-tight (according to EN 12266-1).

Specifications

Valve type	Control Ball Valve
Body pattern	2-way (VBG2-xx-xx), 3-way (VBG3-xx-xx)
Nominal pressure rating	PN25
Media temperature range	+5 ... +120 °C (+41 ... +248 °F)
Connection type	Male BSPP, threaded connections, flat sealing
Controlled fluid	Chilled or hot water according to VDI2035 with up to 50% Glycol. Not for use with steam or fuels.
Leakage rating	
VBG2	Leakage rate A, air bubble-tight according to EN 12266-1
VBG3	Leakage rate A, air bubble-tight according to EN 12266-1 for A-AB port, Rate I according to EN 1349 and EN 60534-4 for B-AB port (0.1% of k_v)
Capacity index (k_{vs})	see Table 1 and Table 2
Close-off pressures	see Table 1 and Table 2
Materials:	
Body	DZR Brass
Stem	Brass
Ball	Chrome-plated brass
Seat	Teflon® seals with EPDM O-rings
Flow control insert	Noryl®
Body Style:	
2-way ball valve	Straight-through flow, full or reduced port using patented flow control insert
3-way ball valve	A-B-AB flow, full or reduced port using patented flow control insert
Body pressure rating	PN25
Flow Characteristics:	
2-way	Equal percentage with flow control insert
3-way	Port A to AB: Equal percentage; Port B to AB: Linear
Approvals/Standards	CE

Table 1. VBG2 Two-way control ball valves

DN	K _{vs} A-B	O.S. no.	Close-off pressure with MVN Rotary Valve Actuators (kPa)	External thread size
15	0.25	VBG2-15-0.25	890	1"
	0.4	VBG2-15-0.4		
	0.63	VBG2-15-0.63		
	1	VBG2-15-1		
	1.6	VBG2-15-1.6		
	2.5	VBG2-15-2.5		
	4	VBG2-15-4		
20	6.3	VBG2-15-6.3	890	1 ¼"
	4	VBG2-20-4		
	6.3	VBG2-20-6.3		
25	8.6	VBG2-20-8.6	680	1 ½"
	6.3	VBG2-25-6.3		
	10	VBG2-25-10		
	16	VBG2-25-16		
32	25	VBG2-25-25	270	2"
	16	VBG2-32-16		

Table 2. VBG3 Three-way control ball valves

DN	k _{vs} A-B	k _{vs} B-AB	O.S. no.	Close-off pressure with MVN Rotary Valve Actuators (kPa)	External thread size
15	0.63	0.5	VBG3-15-0.63	340	1"
	1	0.8	VBG3-15-1		
	1.6	1.28	VBG3-15-1.6		
	2.5	2	VBG3-15-2.5		
	4	3.2	VBG3-15-4		
	6.3	5.04	VBG3-15-6.3		
20	4	3.2	VBG3-20-4	340	1 ¼"
	6.3	5.04	VBG3-20-6.3		
	8.6	6.88	VBG3-20-8.6		
25	6.3	5.04	VBG3-25-6.3	340	1 ½"
	10	8	VBG3-25-10		
	16	12.8	VBG3-25-16		
32	16	12.8	VBG3-32-16	270	2"
	25	20	VBG3-32-25		

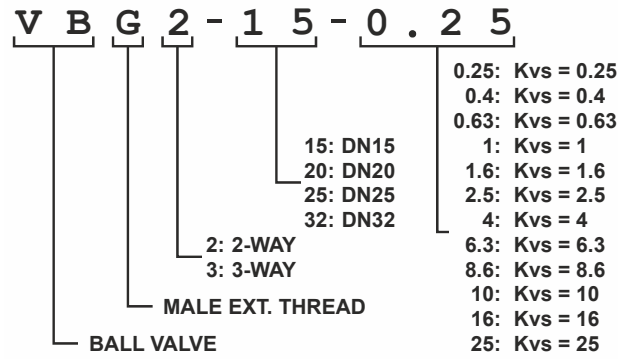


Fig. 1. VBG product key

Table 3. Valve accessories and replacement parts

Part no.	Description
5112-19	Replacement stem assembly for VBG, DN15-20
5112-20	Replacement stem assembly for VBG, DN25-32
MVNAAA	Replacement valve adaptor, standard profile, pre-assembled on the VBG valves
AC-15TF-1	Fittings accessories DN15 VBG valves
AC-20TF	Fittings accessories DN20 VBG valves
AC-25TF	Fittings accessories DN25 VBG valves
AC-32TF	Fittings accessories DN32 VBG valves

Table 4. Connection sets



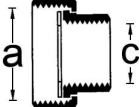
Connection	Pipe size	DN	O.S. no.	Connection set	Description
Internal thread	R ½"	15	AC-15TF-1		
	R ¾"	20	AC-20TF		
	R 1"	25	AC-25TF		
	R 1-¼"	32	AC-32TF		

Table 5. Connection set dimensions

Connection set	a	c	O.S. no.
	G 1"	G 1/2"	AC-15TF-1
	G 1-1/4"	G 3/4"	AC-20TF
	G 1-1/2"	G 1"	AC-25TF
	G 2"	G 1-1/4"	AC-32TF

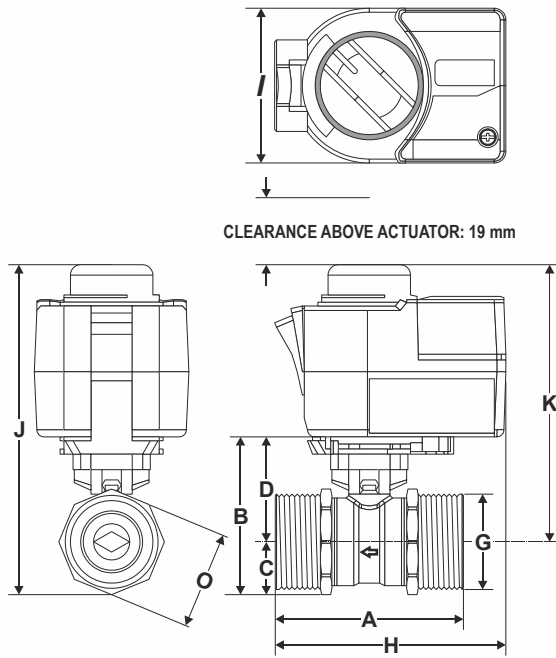


Fig. 2. MVN with 2-way ball valve (see also Table 6)

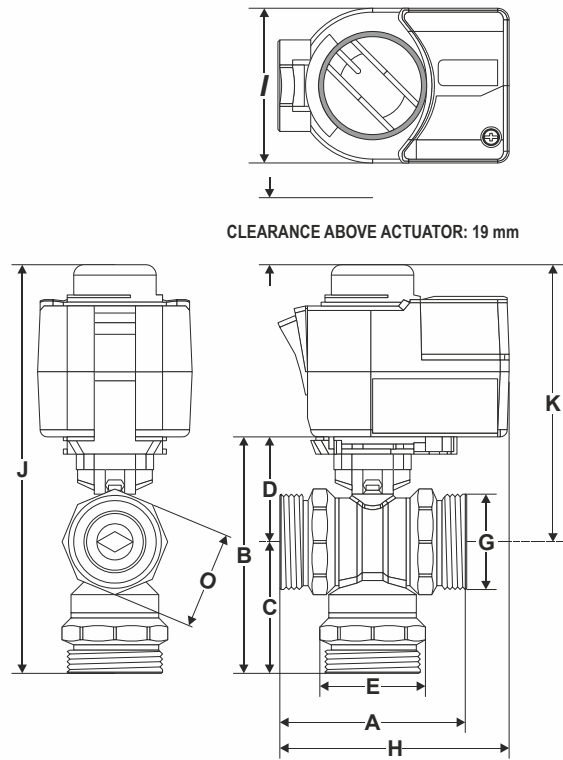


Fig. 3. MVN with 3-way ball valve (see also Table 7)

Table 6. VBG2 dimensions (in mm)

DN	A	B	C	D	G	H	I	J	K	O
15	74.0	67.1	19.1	48.0	G1"	92.3	71.0	142.1	123.0	36.0
20	85.5	77.2	24.7	52.7	G1¼"	98.05	71.0	152.2	127.7	46.0
25	84.5	84.1	26.8	57.5	G1½"	97.55	71.0	159.1	132.5	50.0
32	102.0	98.1	36.0	63.4	G2"	106.3	71.0	173.1	138.4	65.0

Table 7. VBG3 dimensions (in mm)

DN	A	B	C	D	E	G	H	I	J	K	O
15	74.0	107.1	41.1	49.1	44.0	G1"	92.3	71.0	182.1	124.1	41.0
20	85.5	109.4	46.9	49.1	49.5	G1¼"	98.05	71.0	184.4	124.1	46.0
25	84.5	118.4	44.4	53.1	53.5	G1½"	97.55	71.0	193.4	128.1	50.0
32	107.5	142.3	50.9	63.0	69.0	G2"	109.05	71.0	217.3	138.0	65.0

Mounting

When installing the valve care must be taken that the flow direction is correct (see section "Typical Operation" below). The valve must not be mounted with the stem pointing downward.

The valve is supplied complete with mounting instructions. The water quality must meet VDI 2035 requirements.

NOTE: Mount the actuator by hand, only. Do not use a tool, as this could result in damage

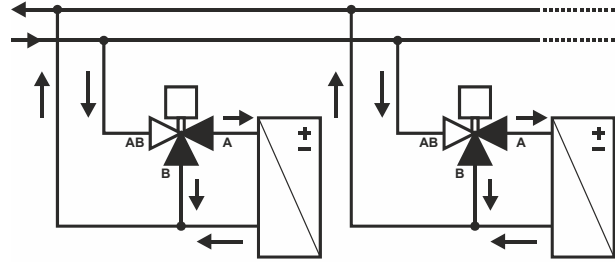


Fig. 6. Three-way diverting valve operation

Typical Operation

All types of valves should be mounted in the return flow. If the D_p -values exceed 300 kPa, attention should be paid to the development of noise.

Two-Way Valves

Direction of flow always from port A to port B

Port B: Outlet

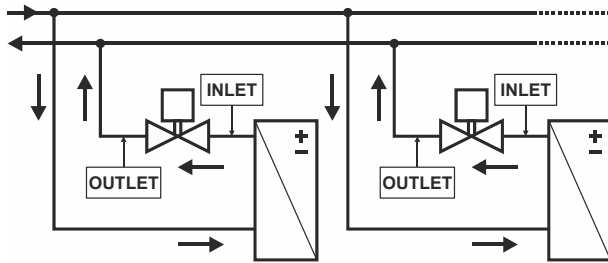


Fig. 4. Two-way valve operation

Three-Way Valves

These valves are used preferably as mixing valves. This means:

Port AB: Total flow outlet

Port A: Controlled flow inlet

Port B: Bypass inlet

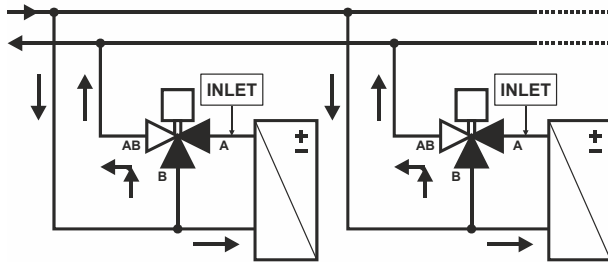


Fig. 5. Three-way mixing valve operation

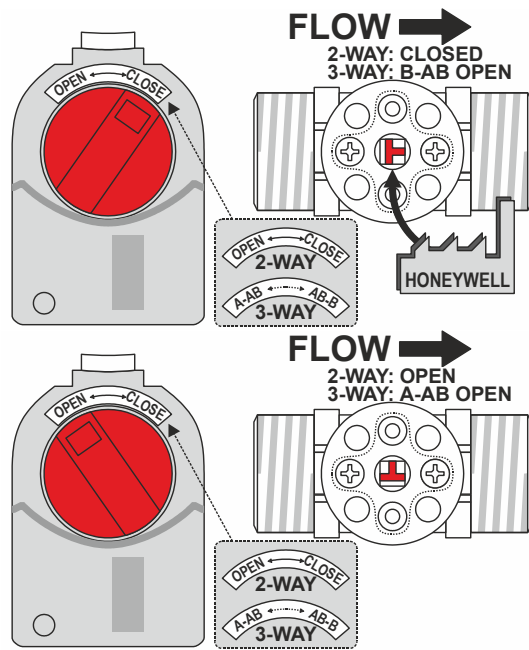


Fig. 7. Orientation of ball in valve

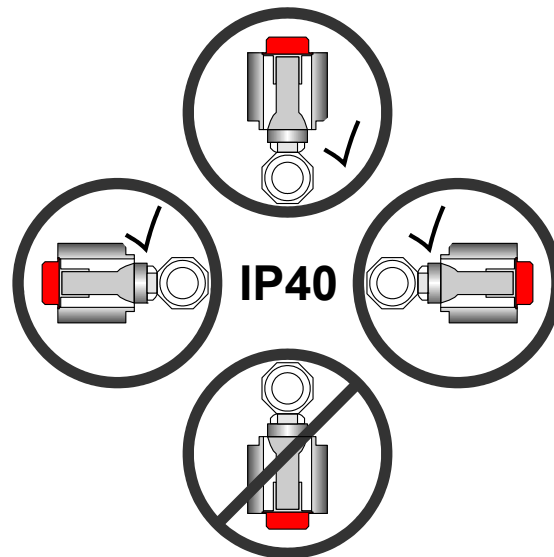


Fig. 8. Acceptable valve orientation

DISPOSAL OF VBG CONTROL BALL VALVES

OBSERVE LOCAL REQUIREMENTS ON PROPER WASTE RECYCLING / DISPOSAL!

- Dezincification-resistant brass body
- Chrome-plated brass ball
- Teflon® seals with EPDM O-rings
- Noryl® flow control insert

Automation and Control Solutions

Honeywell GmbH
 Böblinger Strasse 17
 71101 Schönaich, Germany
 Phone +49 (0) 7031 637 01
 Fax +49 (0) 7031 637 740
<http://ecc.emea.honeywell.com>